

36021 V5Z

80 LB. (36KG) CAPACITY
RIGID-MOUNT WASHER-EXTRACTOR

SPECIFICATION SHEET

FRONT VIEW

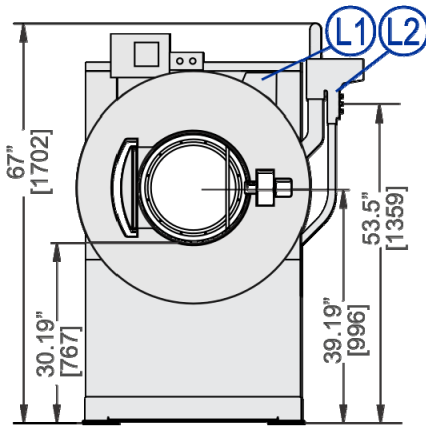

RIGHT SIDE VIEW

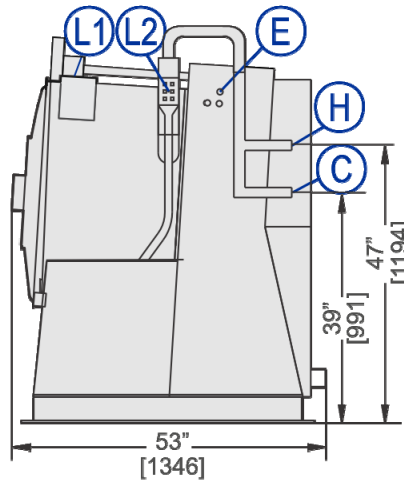

REAR VIEW

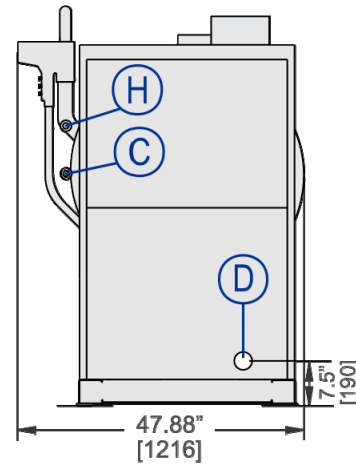

FOUNDATION VIEW

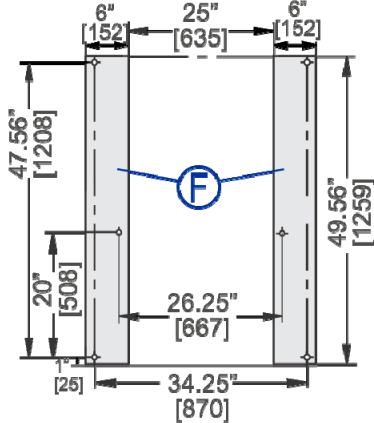

ANCHORING DETAIL

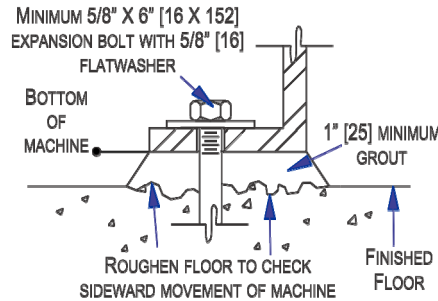

FLOOR REQUIREMENT 12" MINIMUM
RECOMMENDED ▼, ◇

LEGEND

C	Cold water inlet, .75" (19 mm) NPT
D	Drain to rear, 3" (76 mm) pipe socket joint
E	Main electrical connection
F	Foundation base pads, anchor bolt holes .8125" (21 mm) diameter
H	Hot water inlet, .75" (19 mm) NPT
L1	Standard soap chute
L2	Liquid supply inlets

MECHANICAL SPECIFICATIONS

Capacity – lbs (kg)	80 (36)
Cylinder Diameter x Depth – ins (mm)	36 x 21 (914 x 533)
Door Opening – ins (mm)	18 (457)
Cylinder Volume – cu. ft. (L)	12.37 (350)
Machine Dimensions (W x D x H) – ins (mm)	47.88 x 53 x 67 (1216x1346x1702)
Shipping Dimensions (W x D x H) – ins (mm)	85 x 66 x 73 (2159x1676x1854)
Motor – HP (kW)	7.5 (5.59)
Wash Speeds – RPM	25-45
Distribution Speed – RPM	65
Extraction Speeds – RPM	200-550
Extraction G-Force	150
Static Weight – lbs (kg) ◇	1920 (871)
Max. Dynamic Load RMS - lbs (kg) ◇	2122 (963)
Frequency (Hz)	9.03
Water Pressure (Required) – psi (bar)	10-75 (.68-5.1)
Water Valve CV Rating – gal/min (L/min)	6.5 (24)
Minimum Recommended Distance Between Machines – ins (mm)	12 (305)

ELECTRICAL SPECIFICATIONS

Voltage	Running Amps	Fuse (Amps)	Circuit Breaker (Amps)
208-220/3/60	9	FRN20	20
220/3/50	9	FRN20	20
240/3/60	9	FRN20	20
380/3/50-60	5.7	FRS15	15
415/3/50	4.5	FRS15	15
480/3/60	4.5	FRS15	15

See Fuse and Wire Size manual MAEFUSE1BE for safety information. Contact factory for electrical specifications if equipped with Electrical Heat option.

▼ See dimensional drawing for complete details.

◇ It is the sole responsibility of the owner/user to assure that the floor and/or any other supporting structure exceeds not only all applicable building codes, but also that the floor and/or any other supporting structure for each washer-extractor or group of washer-extractors has sufficient strength and rigidity (i.e., a natural or resonant frequency many times greater than the rotational machine speed with a reasonable factory of safety) to support the weight of all the fully loaded machine(s) including the weight of the water and goods, and including the published 360° rotating sinusoidal RMS forces that are transmitted by the machine(s). Contact the factory for additional machine data for use by a structural engineer.



36021 V5Z

80 LB. (36KG) CAPACITY

RIGID-MOUNT WASHER-EXTRACTOR

SPECIFICATION SHEET

Standard Features:

- RinSave® water saving technology
- 7 speeds (2 wash, 1 distribution, 1 RinSave, 3 extract)
- MilTouch™ programmable controller
- Back-lit LCD display
- Single-motor inverter drive
- Tall, lifting ribs
- Tapered roller bearings
- High M.A.F. (Mechanical Action Factor)
- Large cylinder perforations
- Fresh-water flushing chemical manifold
- Auto tension V-belt drive
- Six (6) liquid chemical injection ports
- Control reads in English/second language
- 5-year limited warranty on frame, cylinder & shell



Optional Features:

- Steam
- Electric Heat
- 5 compartment flushing supply injector
- Prison package

Why Purchase Milnor?

- RinSave® water saver in conjunction with large cylinder perforations provides more efficient rinsing. **BENEFIT: Saves water, energy, and time.**
- Larger cylinder volume than most competitive, similar sized washer-extractors provides *greater productivity*. More linen washed per day, or fewer hours required to process. **BENEFIT: Saves labor.**
- Faster process times reduce fabric wear, promoting *longer linen life!* **BENEFIT: Saves linen replacement costs.**
- Tall perforated ribs provide excellent lifting. **BENEFIT: Greater mechanical action leads to better wash quality.**
- 150-G high extract provides excellent moisture removal. Lower extract speeds are available for uniforms, delicate textiles and blended fabrics. **BENEFIT: Better extraction saves dryer fuel.**
- MilTouch™ touch screen control, utilizing resistive touch screen technology and full VGA resolution, has a clear and informative display which shows current machine status info including total formula time and time elapsed. Formulas can be developed on a PC, saved to USB external memory and uploaded with a screen touch. Controller also provides intuitive fault diagnosis and relevant troubleshooting suggestions. **BENEFIT: Fewer operator errors.**
- Superior product support through local, highly-skilled dealers. **BENEFIT: Faster repairs mean less downtime.**



Safe chemical injection

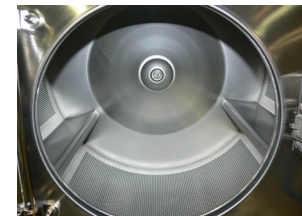

Superior cylinder design

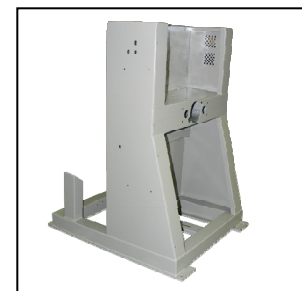

Solid industrial frame

Contact Milnor for your local, authorized dealer:

Pellerin Milnor Corporation
P.O. Box 400 • Kenner, LA 70063
t: 504-467-9591 • f: 504-468-3094

